

# Hexadecimal and Numeric Indicators

## Technical Data

**5082-7300**  
**5082-7302**  
**5082-7304**  
**5082-7340**

### Features

- **Numeric 5082-7300/-7302**  
0-9, Test State, Minus Sign, Blank States  
Decimal Point  
7300 Right Hand D.P.  
7302 Left Hand D.P.
- **Hexadecimal 5082-7340**  
0-9, A-F, Base 16 Operation  
Blanking Control, Conserves Power  
No Decimal Point
- **DTL/TTL Compatible**
- **Includes Decoder/Driver with 5-Bit Memory**  
8421 Positive Logic Input
- **4 x 7 Dot Matrix Array**  
Shaped Character, Excellent Readability

- **Standard Dual-in-Line Package Including Contrast Filter**  
15.2 mm x 10.2 mm (0.6 inch x 0.4 inch)
- **Categorized for Luminous Intensity**  
Assures Uniformity of Light Output from Unit to Unit within a Single Category

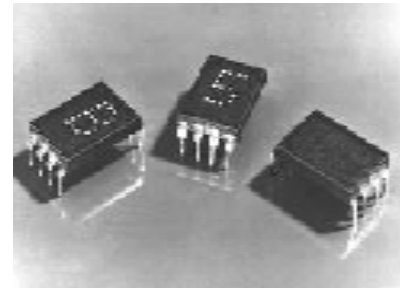

### Description

Agilent's 5082-7300 series solid state numeric and hexadecimal indicators with on-board decoder/driver and memory provide 7.4 mm (0.29 inch) displays for reliable, low-cost methods of displaying digital information.

The 5082-7300 numeric indicator decodes positive 8421 BCD logic inputs into characters 0-9, a “\_” sign, a test pattern, and four blanks in the invalid BCD states. The unit employs a right-hand decimal point.

### Package Dimensions

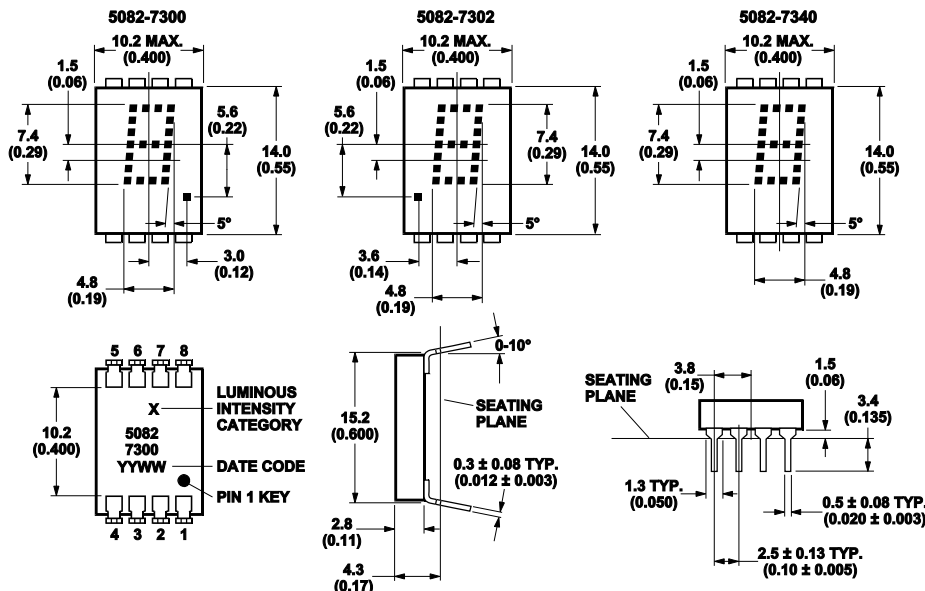

PIN	FUNCTION	
	5082-7300 and 7302 NUMERIC	5082-7340 HEXADECIMAL
1	INPUT 2	INPUT 2
2	INPUT 4	INPUT 4
3	INPUT 8	INPUT 8
4	DECIMAL POINT	BLANKING CONTROL
5	LATCH ENABLE	LATCH ENABLE
6	GROUND	GROUND
7	V <sub>CC</sub>	V <sub>CC</sub>
8	INPUT 1	INPUT 1

- NOTES:**
1. DIMENSIONS IN MILLIMETERS AND (INCHES).
  2. UNLESS OTHERWISE SPECIFIED, THE TOLERANCE ON ALL DIMENSIONS IS  $\pm 0.38$  mm ( $\pm 0.015$  INCH).
  3. DIGIT CENTER LINE IS  $\pm 0.25$  mm ( $\pm 0.01$  INCH) FROM PACKAGE CENTER LINE.

The 5082-7302 is the same as the 5082-7300, except that the decimal point is located on the left-hand side of the digit.

The 5082-7340 hexadecimal indicator decodes positive 8421 logic inputs into 16 states, 0-9 and A-F. In place of the decimal point

an input is provided for blanking the display (all LEDs off), without losing the contents of the memory. Applications include terminals and computer systems using the base-16 character set.

The 5082-7304 is a ( $\pm 1$ ) overrange display including a right-hand decimal point.

### Applications

Typical applications include point-of-sale terminals, instrumentation, and computer systems.

### Absolute Maximum Ratings

Description	Symbol	Min.	Max.	Unit
Storage Temperature, Ambient	$T_S$	-40	+100	°C
Operating Temperature, Case	$T_C$	-20	+85	°C
$V_{CC}$ Pin Potential to Ground Pin	$V_{CC}$	-0.5	+7.0	V
Voltage Applied to Input Logic Pins and Decimal Point <sup>[1]</sup>				
Voltage Applied to Latch Enable	$V_E$	-0.5	+5.5	V
Voltage Applied to Blanking Control <sup>[2]</sup>	$V_B$	-0.5	+5.5	V

**Notes:**

1. Decimal point applies only to 7300/7302.
2. Applies only to 7340.

### Recommended Operating Conditions

Description	Symbol	Min.	Nom.	Max.	Unit
Supply Voltage	$V_{CC}$	4.5	5.0	5.5	V
Logic Voltage "0" State	$V_{IN(0)}$	0		0.8	V
Logic Voltage "1" State	$V_{IN(1)}$	2.0		5.25	V
Latch Enable Voltage – Data Being Entered	$V_{E(0)}$	0		0.8	V
Latch Enable Voltage – Data Not Being Entered	$V_{E(1)}$	2.0		5.25	V
Blanking Control Voltage – Display Not Blanked <sup>[1]</sup>	$V_{B(0)}$	0		0.8	V
Blanking Control Voltage – Display Blanked <sup>[1]</sup>	$V_{B(1)}$	3.5		5.25	V

**Note:**

1. Applies only to 7340.

**Electrical/Optical Characteristics** ( $T_A = -20^\circ\text{C}$  to  $+85^\circ\text{C}$ , Unless Otherwise Specified)

Description	Symbol	Test Conditions	Min.	Typ.	Max.	Unit
Supply Current	$I_{CC}$	$V_{CC} = 5.5\text{ V}$		94 <sup>[1]</sup>	170 <sup>[2]</sup>	mA
Power Dissipation	$P_T$	$V_{CC} = 5.5\text{ V}$		470 <sup>[1]</sup>	935 <sup>[2]</sup>	mW
Luminous Intensity per LED (Digit Average) <sup>[3]</sup>	$I_V$	$V_{CC} = 5.5\text{ V}, T_C = 25^\circ\text{C}$	32	70		$\mu\text{cd}$
Minimum Time Data Must Be Presented to Logic Input Prior to Enable Rising	$t_{\text{SETUP}}$	$V_{CC} = 5.0\text{ V}, V_{E(0)} = 0.4\text{ V}$ $V_{IN(0)} = 0.4\text{ V}, V_{E(1)} = 2.4\text{ V}$ $V_{IN(1)} = 2.4\text{ V}, T_C = 25^\circ\text{C}$		30	50	ns
Minimum Time Data Must Be Held After Enable Rises	$t_{\text{HOLD}}$	$V_{CC} = 5.0\text{ V}, V_{E(0)} = 0.4\text{ V}$ $V_{IN(0)} = 0.4\text{ V}, V_{E(1)} = 2.4\text{ V}$ $V_{IN(1)} = 2.4\text{ V}, T_C = 25^\circ\text{C}$		30	50	ns
Time Required for 90% Change in Display Luminous Intensity After Change of State of $F_B$ <sup>[4]</sup>	$t_{\text{BLANK}}$	$V_{CC} = 5.0\text{ V}, T_C = 25^\circ\text{C}$			500	ns
Blanking Control Current "0" State <sup>[4]</sup>	$I_{B(0)}$	$V_{CC} = 5.5\text{ V}, V_{B(0)} = 0.8\text{ V}$			200	$\mu\text{A}$
Blanking Control Current "1" State <sup>[4]</sup>	$I_{B(1)}$	$V_{CC} = 5.5\text{ V}, V_{B(1)} = 4.5\text{ V}$			2.0	mA
Logic and Latch Enable Currents "0" State	$I_{IN(0)},$ $I_{E(0)}$	$V_{CC} = 5.5\text{ V}$ $V_{IN}, V_E = 0.4\text{ V}$			-1.6	mA
Logic and Latch Enable Currents "1" State	$I_{IN(1)},$ $I_{E(1)}$	$V_{CC} = 5.5\text{ V}$ $V_{IN}, V_E = 2.4\text{ V}$			+250	$\mu\text{A}$
Peak Wavelength	$\lambda_{\text{PEAK}}$	$T_C = 25^\circ\text{C}$		655		nm
Spectral Halfwidth	$\Delta\lambda_{1/2}$	$T_C = 25^\circ\text{C}$		30		nm
Weight				0.8		gm

**Notes:**

- $V_{CC} = 5.0\text{ V}$  with statistical average number of LEDs lit.
- Worst case condition excluding test state on 5082-7300/-7302.
- The digits are categorized for luminous intensity such that the variation from digit to digit within a category is not discernible to the eye. Intensity categories are designated by a letter located on the reverse side of the package contiguous with the Agilent logo marking.
- Applies only to -7340.

**Truth Table for 5082-7300 Series Devices**

Character		Input						Character		Inputs					
5082-7300/7302 Numeric	5082-7340 Hex.	X8	X4	X2	X1	E	B <sup>[1]</sup>	5082-7300/7302 Numeric	5082-7340 Hex.	X8	X4	X2	X1	E	B <sup>[1]</sup>
0	0	L	L	L	L	L		Test	A	H	L	H	L	L	L
1	1	L	L	L	H	L	L	Blank	B	H	L	H	H	L	L
2	2	L	L	H	H	L	L	Minus	D	H	H	L	H	L	L
3	3	L	L	H	H	L	L	Minus	D	H	H	L	H	L	L
4	4	L	H	L	L	L	L	Blank	E	H	H	H	L	L	L
5	5	L	H	L	H	L	L	Blank	F	H	H	H	H	L	L
6	6	L	H	H	L	L	L	Hold	Hold	d	d	d	d	H	d
7	7	L	H	H	H	L	L	-	Blank <sup>[1]</sup>	d	d	d	d	d	H
8	8	H	L	L	L	L	L	Decimal pt. on <sup>[2]</sup>	-	$DP_{IN} = L$					
9	9	H	L	L	H	L	L	Decimal pt. off <sup>[2]</sup>	-	$DP_{IN} = H$					

**Notes:**

- The blanking control input, B, pertains to the 5082-7340 Hexadecimal Indicator only.
- The decimal point input pertains to the 5082-7300 and -7302 Numeric Indicators only.
- H = logic '1'; L = logic '0'; d = 'don't care.'

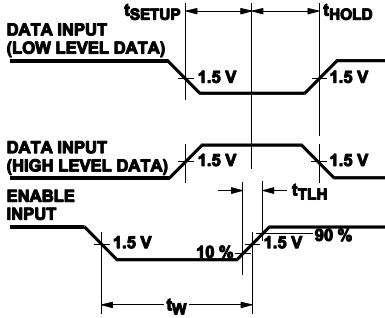

Figure 1. Timing Diagram of 5082-7300 Series Logic.

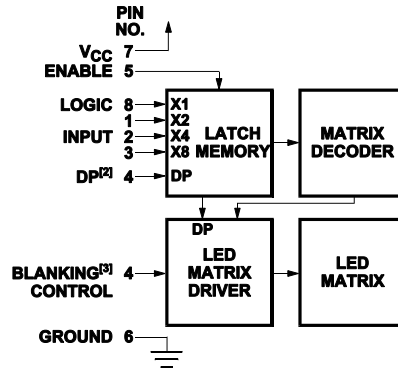

Figure 2. Block Diagram of 5082-7300 Series Logic.

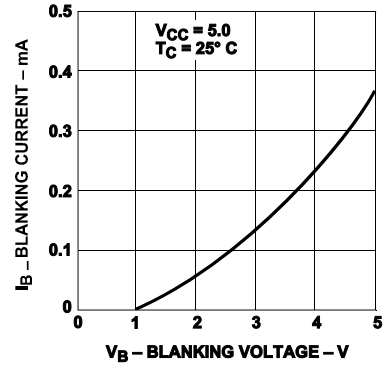

Figure 3. Typical Blanking Control Current vs. Voltage for 5082-7340 Only.

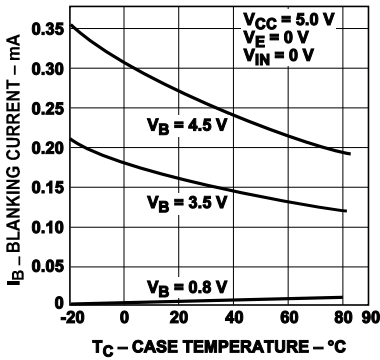

Figure 4. Typical Blanking Control Input Current vs. Ambient Temperature, 5082-7340.

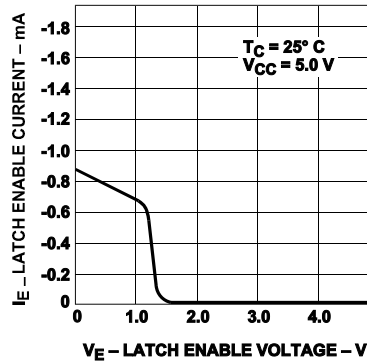

Figure 5. Typical Latch Enable Input Current vs. Voltage for the 5082-7300 Series Devices.

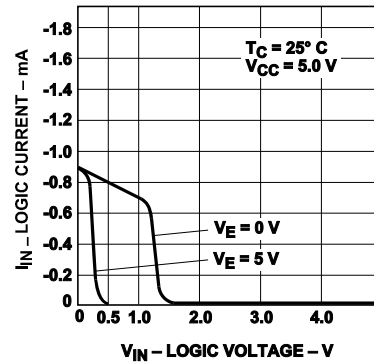

Figure 6. Typical Logic and Decimal Point Input Current vs. Voltage for the 5082-7300 Series Devices. Decimal Point Applies to 5082-7300 and -7302 Only.

TRUTH TABLE					
BCD DATA <sup>[1]</sup>				5082-7300/7302	5082-7340
X <sub>8</sub>	X <sub>4</sub>	X <sub>2</sub>	X <sub>1</sub>		
L	L	L	L	0	0
L	L	L	H	1	1
L	L	H	L	2	2
L	L	H	H	3	3
L	H	L	L	4	4
L	H	L	H	5	5
L	H	H	L	6	6
L	H	H	H	7	7
H	L	L	L	8	8
H	L	L	H	9	9
H	L	H	L	A	A
H	L	H	H	(BLANK)	B
H	H	L	L	(BLANK)	C
H	H	L	H	...	D
H	H	H	L	(BLANK)	E
H	H	H	H	(BLANK)	F

DECIMAL PT. <sup>[2]</sup>	ON	V <sub>DP</sub> = L
	OFF	V <sub>DP</sub> = H
ENABLE <sup>[1]</sup>	LOAD DATA	V <sub>E</sub> = L
	LATCH DATA	V <sub>E</sub> = H
BLANKING <sup>[3]</sup>	DISPLAY-ON	V <sub>B</sub> = L
	DISPLAY-OFF	V <sub>B</sub> = H

**NOTES:**

1. H = LOGIC HIGH; L = LOGIC LOW. WITH THE ENABLE INPUT AT LOGIC HIGH, CHANGES IN BCD INPUT LOGIC LEVELS OR D.P. INPUT HAVE NO EFFECT UPON DISPLAY MEMORY, DISPLAYED CHARACTER, OR D.P.
2. THE DECIMAL POINT INPUT, DP, PERTAINS ONLY TO THE 5082-7300 AND 5082-7302 DISPLAYS.
3. THE BLANKING CONTROL INPUT, B, PERTAINS ONLY TO THE 5082-7340 HEXADECIMAL DISPLAY. BLANKING INPUT HAS NO EFFECT UPON DISPLAY MEMORY.

**Solid State Over Range Character**

For display applications requiring a ±, 1, or decimal point designation, the 5082-7304 over range character is available. This display module comes in the same package as the 5082-7300 series numeric indicator and is completely compatible with it.

**Package Dimensions**

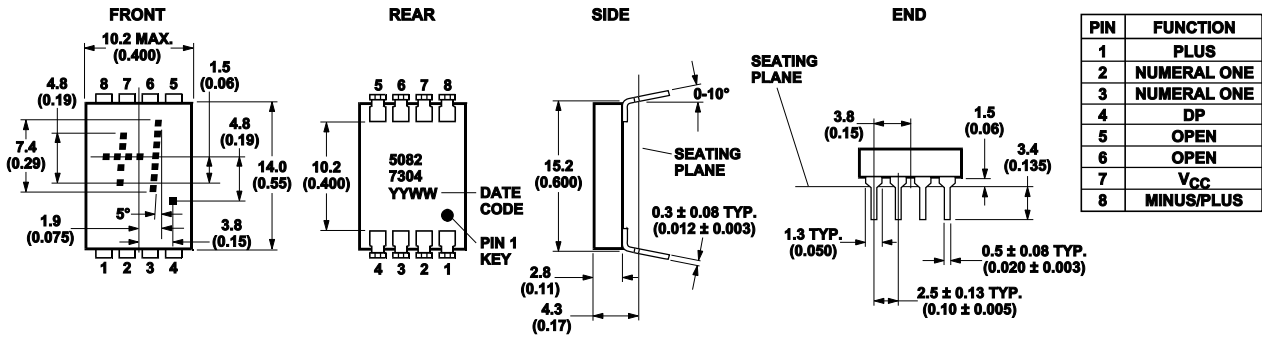

**Truth Table for 5082-7304**

Character	Pin			
	1	2, 3	4	8
+	1	d	d	1
-	0	d	d	1
1	d	1	d	d
Decimal Point	d	d	1	d
Blank	0	0	0	0

**Notes:**

- L: Line switching transistor in Figure 7 cutoff.
- H: Line switching transistor in Figure 7 saturated.
- X: 'Don't care.'

**Typical Driving Circuit for 5082-7304**

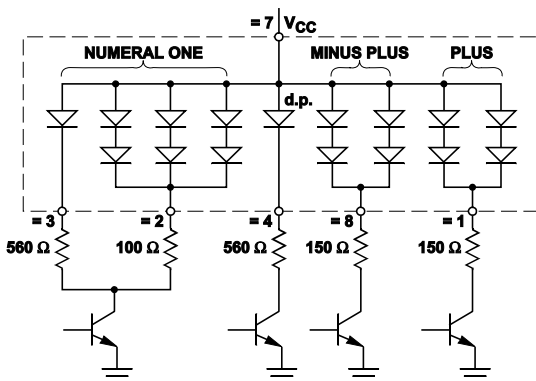
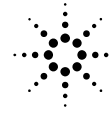

Figure 7.



### Absolute Maximum Ratings

Description	Symbol	Min.	Max.	Unit
Storage Temperature, Ambient	$T_S$	-40	+100	°C
Operating Temperature, Case	$T_C$	-20	+85	°C
Forward Current, Each LED	$I_F$		10	mA
Reverse Voltage, Each LED	$V_R$		4	V

### Recommended Operating Conditions

Description	Symbol	Min.	Nom.	Max.	Unit
LED Supply Voltage	$V_{CC}$	4.5	5.0	5.5	V
Forward Current, Each LED	$I_F$		5.0	10	mA

**Note:**

LED current must be externally limited. Refer to Figure 7 for recommended resistor values.

### Recommended Operating Conditions

( $T_A = -20^\circ\text{C}$  to  $70^\circ\text{C}$ , Unless Otherwise Specified)

Description	Symbol	Test Conditions	Min.	Typ.	Max.	Unit
Forward Voltage per LED	$V_F$	$I_F = 10\text{ mA}$		1.6	2.0	V
Power Dissipation	$P_T$	$I_F = 10\text{ mA}$ All Diodes Lit		250	320	mW
Luminous Intensity per LED (Digit Average)	$I_V$	$I_F = 6\text{ mA}$ $T_C = 25^\circ\text{C}$	32	70		$\mu\text{cd}$
Peak Wavelength	$\lambda_{\text{PEAK}}$	$T_C = 25^\circ\text{C}$		655		nm
Dominant Wavelength	$\lambda_d$	$T_C = 25^\circ\text{C}$		30		nm
Weight				0.8		gm

For further information concerning electrical and mechanical implementation of the 5082-7300 series devices, please refer to Application Note 934.